

REVISION AND PRINT RECORD

| REV/PRINTS | TO | DATE | FOR |
|------------|------------------|----------|-------|
| | SKYLINE ELEVATOR | 01/13/06 | APPVL |
| | | | |
| | | | |
| | | | |
| | | | |

OPENING: (44" x 84")
1 SET CAR DOOR 2 SPD

- 1 DOOR SETS REQUIRED.
R.H. L.H.
HAND OF DOORS
- 2 DOOR PANELS: 1" x 23 3/8" x 84 1/2"
- DOORS FINISH: #4 STN. STL.
- DOORS REQUIRED: (2 PER DOOR)
- 4 GIBBS REQUIRED: (2 PER DOOR)
- DOOR DRILLING: (ADVISE)

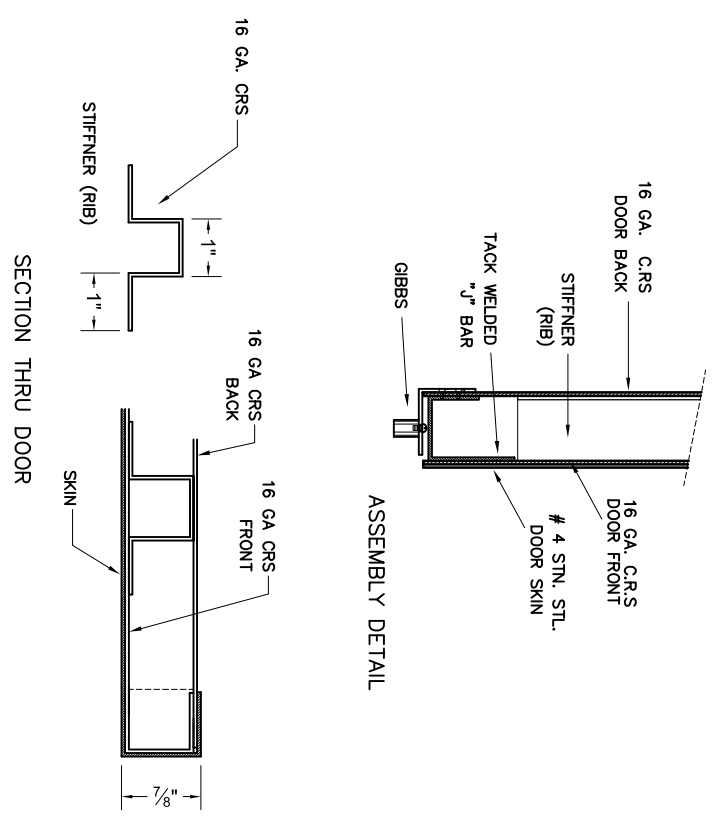
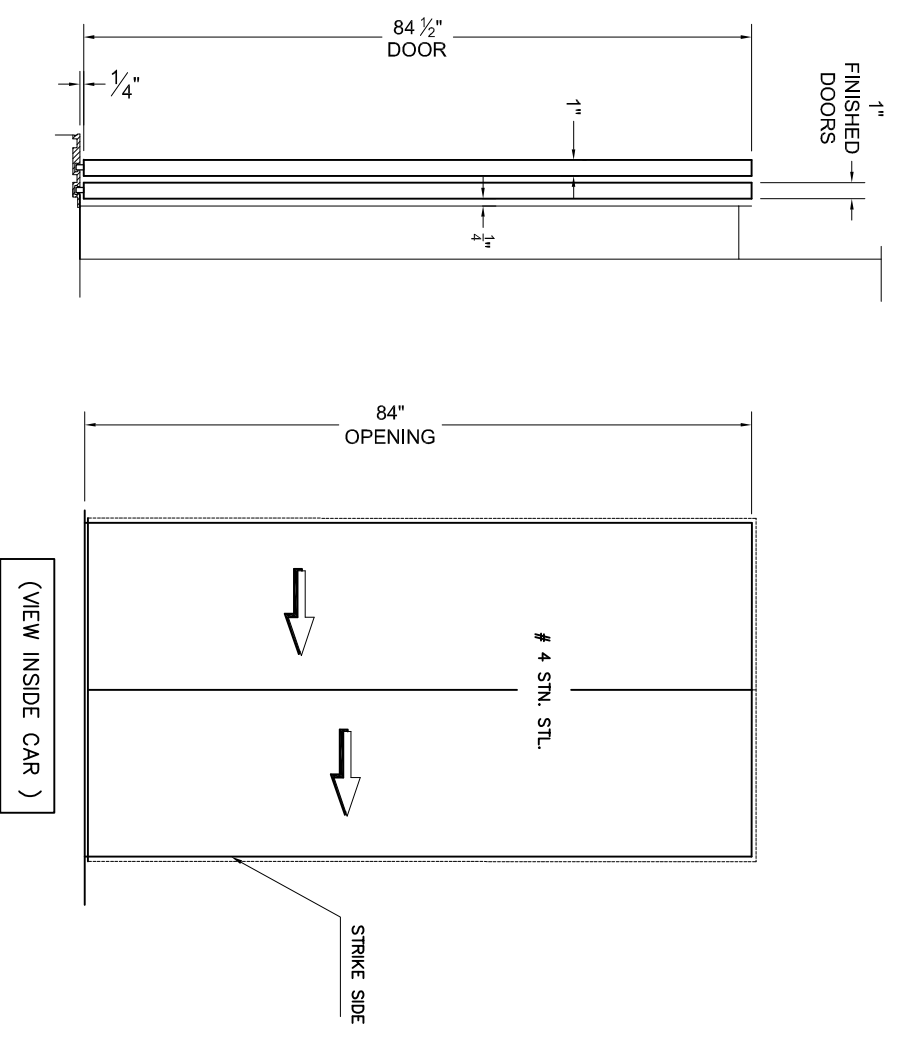
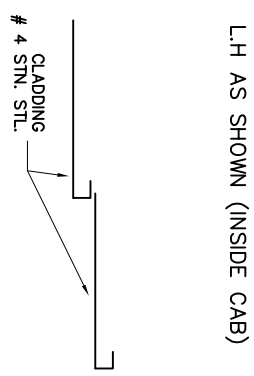
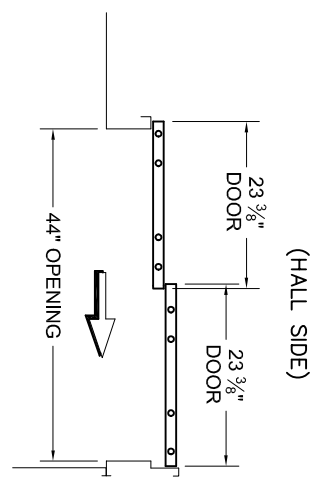
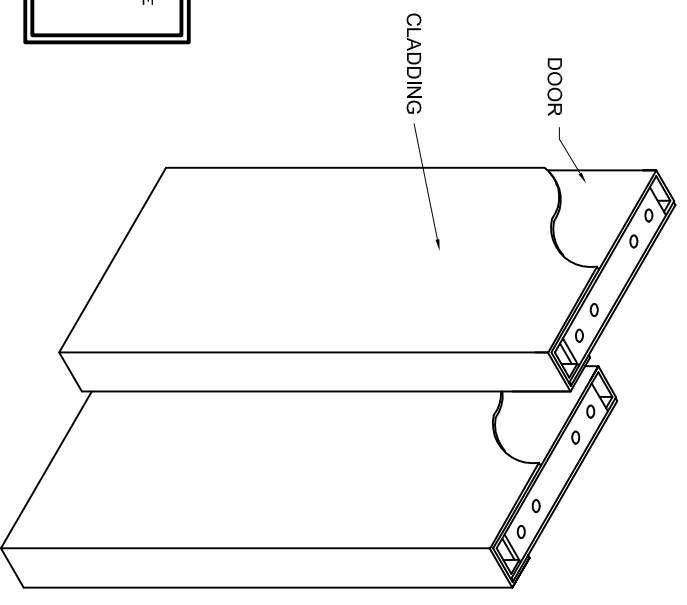
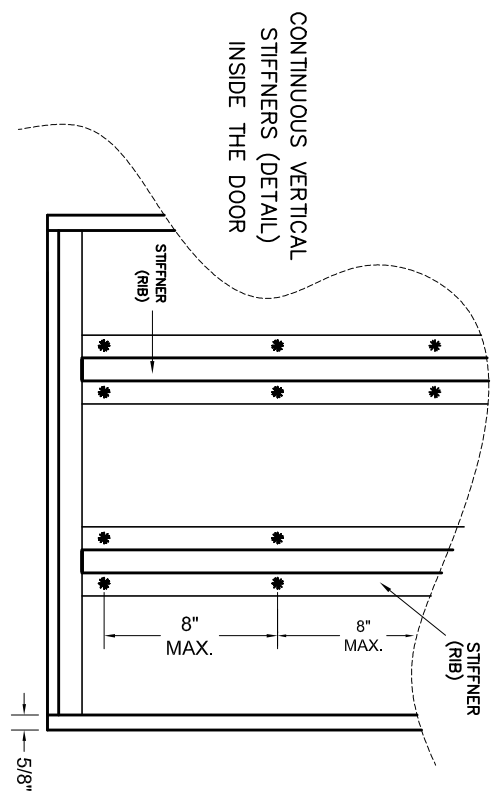

NOTE:
PLEASE ELEVATOR CONTRACTOR TO ADVISE
THE FOLLOWING INFORMATION A.S.A.P:
1-DOOR DRILLING DATA.

1 SET CAR DOOR L.H 2 SPD AS SHOWN

CONCEPT ELEVATOR.
GROUP, LLC.

9100A N.W. 66th STREET, DORAL, FL 33176.
(786)-946-9966 • TOLL FREE 866-608-8965 • Fax (786)946-8961

CUSTOMER: SKYLINE ELEVATOR
JOB NAME: VAMC
LOCATION: TUCSON AZ
ARCHITECT:
DRAWN BY: MARTINEZ
JOB NO. CUSTOMER NO. P. ORDER NO. SHEET NO.
06-11134-D # 2530 1 OF 2

UNLESS OTHERWISE SPECIFIED

| TOLERANCES |
|---|
| 1" (1.00) 25.4 MM OR LESS ±1/32 (.031) .793 MM |
| OVER 1" (1.00) 25.4 MM LESS THAN 12" (12.00) 304.80 MM ±1/16" (.0625) 1.58 MM |
| OVER 12" (12.00) 304.80 MM LESS THAN 60" (60.00) 1524 MM ±1/8" (.125) 3.18 MM |
| OVER 60" (60.00) 1524 MM TO 120" (120.00) 3048 MM ±1/4" (.250) 6.35 MM |